

## What is the function of a Router and where is it used ?

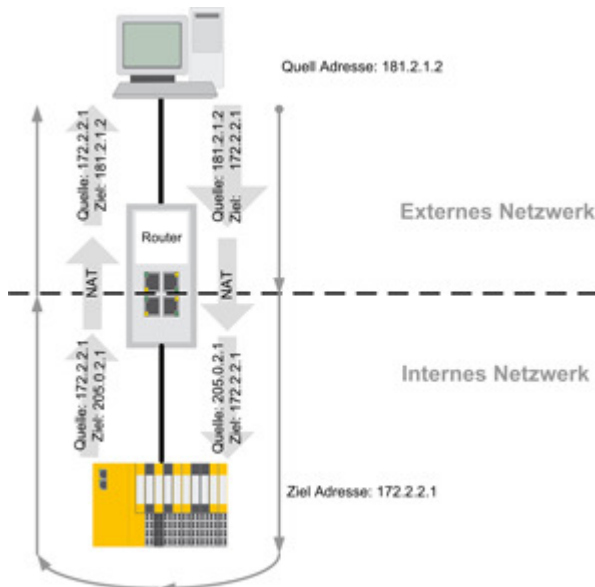

A **router** is a device from the field of computer networking and internet, which is used to connect or separate multiple Ethernet networks. Now that the industrial Ethernet has entered into automation technology, these are also often used in the industrial field.

### Method of Operation

The router analyses the incoming data packet according to its destination and either blocks or forwards the packet (the packets are routed). Forwarded packets land in one of the router's directly connected end points (also end sub network) or are forwarded to another router in a directly connected network. The router uncouples the information behind the router from the information in front of the router. This means the addresses within the subnet can be allocated without significance to the addresses outside of

the subnet. For this a so-called NAT process (Network Address Translation) takes place within the router. Routers function in layer 3 (Network Layer) of the OSI reference model. A router uses multiple interfaces which are accessible through the network. These interfaces can also be virtual. On receiving a data packet the router must select the best route and therefore the most suitable interface, on which to forward the data. To do so the router accesses a local routing table which states which router connection is accessible from which network. There may also be a *Default-Route* available in the routing table. This route usually shows a higher ranking route often known as the Standard Gateway. Routers can only forward data packets suitable for routing. The following protocols are suitable for routing: TCP / IP or UDP / IP (see also the September newsletter).

In the industrial field, specialised industrial routers in a robust design with a case, are suitable for installation within a switchboard. Depending on the type of application and price range, industrial routers can offer a variety of functions. Routers often have DSL, ISDN or GSM modems integrated in order to enable the in-house LAN connection within the company (Local Area Network) to access the outside world. Furthermore a Firewall can be integrated.

### The function of routers in SafetyNET p networks.

Routers can also be installed in SafetyNET p. The UDP / IP protocol installed at SafetyNET p in the RTFN version (Real Time Frame Network) is suitable for routing without any restriction. This enables SafetyNET p networks to be connected to each other outside of the network boundary and makes segmentation of complex networks possible. Routers with a firewall function are installed for security reasons. This prevents unauthorised access to network resources. Furthermore routers can be installed in SafetyNET p in order to make remote maintenance concepts possible.